

---

# INSTALLATION AND SERVICE MANUAL

---

## MI-500



# Pending Agency Approvals



Medical Electrical Equipment  
With respect to electric shock, fire  
And mechanical hazards only  
In accordance with IEC60601-1:2006 / CAN/CSA C22.2  
No.601.1-M90 with updates 1 & 2

**Classifications:**

Protection against electrical shock (5.1, 5.2). Class I permanently connected,  
Protection against harmful ingress of water (5.3). None.  
Degree of safety in the presence of flammable anesthetics or oxygen (5.5). Not suitable for use in the  
presence of flammable anesthetics or oxygen.  
Mode of operation (5.6). Continuous  
Surgical luminaries (IEC60601-2-41)



Electromagnetic compatibility for immunity  
And emissions in accordance with  
EN-60601-1-2(2001) Class B and CISPR 22 (1997) Class B

Medical Electrical Equipment  
Particular requirements for the safety of surgical  
luminaries and luminaires for diagnosis  
In accordance with IEC-60601-2-41

**Intended use:** Professional Medical Lighting for Hospital, Clinic, Veterinary, Minor Surgery, Examination or Diagnosis, within suitable facilities designated for such purposes. This light system is mounted centrally in a room such that access is available all around the operating environment.

**User interface:** The MI-500 lighting systems are intended to be used by medical professionals in surgeries and exam rooms. The functional interfaces are up to 345° positioning horizontally (except Floor and Wall models) and vertically  $\pm 40^\circ$ . The lamp head can be rotated approximately 190°. An ON/OFF button is provided with 5 levels of dimming and Endo mode.

**Misuses:** For any purpose or use at any facility other than stated above. Caution shall be exercised when positioning the light head and avoid contact or collision with the patient, other medical professionals or other lights/equipment.

# Table of Contents

<b>Section 1: General Information</b> .....	<b>4</b>
Definition of Terms .....	4
List of symbols.....	5
MI-500 models.....	6
Limited Warranty .....	7
<b>Section 2: Specifications</b> .....	<b>9</b>
Mechanical Specifications .....	9
Electrical Specifications .....	9
Optical Specifications .....	10
Environmental Specifications.....	10
<b>Section 3: Installation/Assembly</b> .....	<b>11</b>
Ceiling Rod Calculation .....	11
Ceiling Calculation: Single Mount Dimensions .....	12
Ceiling Calculation: Double Mount Dimensions .....	13
Ceiling Mount Pre-Installation Guidelines .....	14
Ceiling Structure Construction and Mounting .....	15
Single Ceiling Mount Installation.....	19
Double Ceiling Mount Installation .....	22
Wall Mounted Light Installation.....	27
Floor Stand Light Installation .....	30
Light Head-Arm Installation .....	33
<b>Section 4: Safety and Maintenance Instructions</b> .....	<b>34</b>
Safety Tips.....	34
Fuse Replacement .....	35
LED Maintenance .....	35
Arm Adjustment .....	36
Head/Yoke Adjustment.....	37
Cleaning Instructions .....	38
Maintenance Schedule .....	39
<b>Section 5: Troubleshooting</b> .....	<b>40</b>

# Table of Figures

Figure 1: Single Ceiling Mount Ceiling Rod Calculation .....	12
Figure 2: Double Ceiling Mount Ceiling Rod Calculation .....	13
Figure 3: Recommended Ceiling Structure Construction .....	15
Figure 4: Ceiling Casting Mount Diagram .....	16
Figure 5: Extended Ceiling Mount Installation .....	17
Figure 6: Single Ceiling Mount Installation.....	20
Figure 7: Double Ceiling Mount Installation .....	23
Figure 8: Wire Harness Positioning .....	25
Figure 9: Wire Channel.....	25
Figure 10: Wall Mount Installation .....	27
Figure 11: Wall Bracket Mounting Diagram .....	27
Figure 12. Stud Anchor Installation.....	29
Figure 13: Floor Stand Base Installation.....	30
Figure 14: Arm Assembly to Upright Pole Installation.....	31
Figure 15: Light Head-Arm Installation .....	33
Figure 18: Arm Adjustment.....	36

## Section 1: General Information Definition of Terms

**IEC** – International Electrotechnical Commission

**ETL** – Edison Testing Laboratory

### **Medical Electrical Equipment**

Electrical equipment intended to diagnose, treat the patient under medical supervision. In this application it is the electrical equipment that transfers light energy to the patient.

### **Central Illuminance**

Illuminance of light head measured at 1 meter from the light emitting area with no obstructions. The value is expressed in Foot-candles or LUX.

### **Light Field Center**

This is the point of maximum illuminance in lighted area. This is the reference point for light field size and light distribution measurements

### **Light Field Diameter**

The diameter of the circle where the illuminance reaches 10% of light field center illuminance

### **Depth of Illumination**

The distance above and below 1 meter to where the central illuminance is reduced to 20%

### **Shadow Dilution**

The ability of the equipment to minimize the impact of shadows in the working area due to partial obstruction by the operator or other medical personnel

### **Total Irradiance**

The total amount of energy imparted to the patient by the lighting system expressed in Watts/meter squared

### **Sterilizable Handle**

An easily removable device that when properly sterilized maintains a sterile area in order to handle it under aseptic conditions when attached to the equipment

### **Head/Yoke Assembly**

The light source, heat removal system and light focusing system

### **Arm Assembly – Extension/Articulating Arm**

The horizontal section of the positioning arm that connects to the articulating arm allows for vertical positioning of the light head

### **Light Mounting**

Support apparatus used to connect arm assembly/light head to a fixed surface, consisting of either a single, double or triple ceiling mount.

### **Neutral Conductor (common)**

In an AC circuit, the return line for current.









### **Protective earth ground**

The conductor used to connect the non-current-carrying metal parts of equipment, raceways, and other enclosures to the system grounded conductor, the grounding electrode conductor, or both, of the circuit at the service equipment or at the source of a separately derived system.

### **Off Center Moment Load**

The torque developed by mounting the Light Head at the end of an extended arm. This is measured in foot-pounds.

List of symbols

	<p>ETL Listing Marking</p>
	<p>Read accompanying documents</p>
	<p>C.E. Marking</p>
	<p>Fuse marking</p>
	<p>Protective earth ground</p>
	<p>Neutral conductor</p>
	<p>Caution</p>
	<p>Electric shock hazard</p>
	<p>Separate collection for electric and electronic equipment. Do not dispose of as household waste.</p>

**MI-500 models**

The following MI-500 models are covered in this manual:

061312 Wall Mount.....	100-240 VAC, 1.25A, 50/60 Hz, 60 W
061313 Floor Model.....	100-240 VAC, 1.25A, 50/60 Hz, 60 W
061314 Single Ceiling Mount.....	100-240 VAC, 1.25A, 50/60 Hz, 60 W
061315 Dual Ceiling Mount .....	100-240 VAC, 2.5A, 50/60 Hz, 120 W

**Medical Illumination International, Inc.  
Lighting Equipment**

**Limited Warranty**

This document comprises the general terms of your product's Limited Warranty. By accepting the shipment of the product, the owner/purchaser agrees to adhere to the warranty terms and conditions expressed herein.

Medical Illumination International, Inc. ("Medical Illumination") Lighting Equipment is warranted against defective material and/or workmanship, excluding normal replacement parts (e.g. bulbs, sterilizable handles or glass items), for a period of three (3) years from the date of shipment. This Limited Warranty applies exclusively to the repair or replacement of parts recognized as defective by Medical Illumination that are in normal use and have not been modified or repaired by unauthorized personnel.

This Limited Warranty extends only to the first retail purchaser of a product, and is not transferable or assignable. This warranty supersedes all other guarantees or warranties, expressed or implied.

**WARRANTY SERVICE & REPAIRS**

Medical Illumination does not provide (or give any compensation for) outside repair services or field labor. Therefore, in the event of a failure covered under this warranty, please take the following immediate action:

1. Contact Medical Illumination via phone at (818) 838-3025, through our website at <http://www.medillum.com>, or by facsimile at (818) 838-3725.

A. Be prepared to give the model number, serial number, and full description of the failure.

B. Our Customer Service department will attempt to solve the problem over the phone. If it becomes necessary to send the product to the factory for repair, you will be provided with a Return Authorization number. Products sent to the factory without a Return Authorization number will not be accepted.

2. It is the retail purchaser's obligation to arrange for shipment return of a product to the factory for warranty service, which shall be at the retail purchaser's expense. Carefully package the light component (light head, arm assembly, mount assembly, etc.) and return it, freight prepaid and insured, with the Return Authorization number clearly marked on the outside of the box, to:

Medical Illumination  
547 Library Street  
San Fernando, CA 91340  
RA# \_\_\_\_\_

Damage resulting from inadequate packing is not covered by this warranty, and shipping insurance does not cover damage due to inadequate packing. We recommend that the package be insured against loss or in-transit damage. Medical Illumination cannot be held responsible for in-transit loss or damage. In the event that freight-related damage should occur, Medical Illumination will notify you immediately so that you can file a damage claim with the proper freight carrier.

### Medical Illumination Limited Warranty (cont'd)

Within the aforementioned time period of three (3) years from date of shipment, Medical Illumination will evaluate the returned product, repair as appropriate, and ship the product back to you with freight costs prepaid by the Company. In the event that non-warranty damage or failure is discovered, you will be contacted before any repairs are performed.

#### EXCLUSIONS

*This Limited Warranty does not cover the following:*

- Any field labor or outside services (electricians, contractors, installation services, routine maintenance or other repair services)
- Damage to the product resulting from tampering, accident, abuse, negligence, alteration, or other causes unrelated to problems with material and/or workmanship
- Damage due to improper installation, use, cleaning or maintenance, as outlined in the Installation and Service Manual for the product
- Labor costs associated with removing, re-packaging for shipment or reinstalling product

#### PRODUCT RETURNS:

Please contact the authorized dealer from whom the product was purchased to inquire about a product return. Additional terms and conditions set by the dealer may apply for any returned items.

#### SHIPMENT DAMAGE:

If the initial shipment of your purchased product arrived in damaged condition, please leave the packaging and its contents intact and contact Medical Illumination immediately.

## Section 2: Specifications

### Mechanical Specifications

Parameter	Value
<b>Weight</b>	
Head	Approx 3.5 lbs. (1.6 kg)
Arm	Approx 12.5 lbs. (5.7 kg)
Arm (Floor)	Approx 11.5 lbs. (5.2 kg)
Wall Bracket Assy.	Approx 3.0 lbs. (1.4 kg)
Floor Stand Assy.	Approx 43.0 lbs. (19.5 kg)
Single Ceiling Mount	Approx 14.5 lbs. (6.6 kg)
Dual Ceiling Mount	Approx 16.0 lbs. (7.3 kg)
<b>Dimensions</b>	
Head	Ø6.25" (Ø159 mm) x 6.5" High (165 mm)
Arm	57.0" (1,448 mm) Long
Arm (Floor)	38.5" (978 mm) Long
Floor Stand	74.5" (1,892 mm) High
<b>Rotations</b>	
Articulating Arm Vertical Movement	+/- 40°
Articulating Arm Horizontal Movement	Approx 345 °
Articulating Arm/Yoke Interface	Approx 540°
Yoke/Lamp Head Interface	Approx 190°

### Electrical Specifications

Parameter	Value
Input Voltage	100 – 240 VAC 50/60 Hz
Power Consumption	Approx 50W max
LED life	50,000 hours (average)
<b>Power</b>	
Solo	120/230 VAC, 50/60 Hz 60 Watts
Duo	120/230 VAC, 50/60 Hz 120 Watts

## Optical Specifications

Parameter	Value
8 Inner optics	Clear acrylic, single-source
<b>Performance</b> Color temperature Focal length Central illuminance (full intensity)  Light field diameter (d10) Irradiance CRI	4,300° Kelvin ±300°K 24" (610 mm) 50,000 +/- 5K LUX  Approx Ø6" Approx 128.98 W/m <sup>2</sup> ≥87

## Environmental Specifications

Parameter	Value
Operating Temperature Storage Temperature Range	41°F to 104°F (5° to 40° Celsius) -4°F to 122°F (-20° to 50° Celsius)
Humidity	10 - 90% Relative Humidity
Pressure	100 kPA (@ <2K meters)

## Section 3

### Section 3: Installation/Assembly Ceiling Rod Calculation



Use the following table to select the correct length ceiling rod for your application.

Ceiling Mounting Height		Base Rod	Ext. Rod	Ext. Mnt. Kit	
07'10" – 08'06"	(94" - 102")	16"	-	-	Base Rod Only
08'07" – 09'04"	(103" - 112")	25"	-	-	
09'05" – 10'01"	(113" - 121")	35"	-	-	
10'02" – 10'10"	(122" - 130")	16"	34"	1000976–44	Extension Rod Needed
10'11" – 11'08"	(131" - 140")	25"	34"	1000976–53	
11'09" – 12'00"	(141" - 144")	35"	34"	1000976–63	
12'01" – 12'10"	(145" - 154")	25"	48"	1000976–67	
12'11" – 14'00"	(155" - 168")	35"	48"	1000976–77	

# Ceiling Calculation: Single Mount Dimensions

**!** Use the following table to select the correct length ceiling rod for your application.  
Ceiling Rod Calculation, Single Ceiling Mount

Ceiling Mounting Height "Y"-Value	Ceiling Rod Length	"X"-Value	Head room to bottom of extension arm (Y-Value – X-Value)
8'0" - 8'9"	16"	22"	6'2" – 6'11"
8'10" - 9'7"	25"	31"	6'3" - 7'0"
9'8" - 10'4"	35"	41"	6'3" – 6'11"
10'5" - 11'1"	44"	50"	6'3" – 6'11"
11'2" - 11'11"	53"	59"	6'3" - 7'0"
12'0" - 12'3"	63"	69"	6'3" - 6'6"
12'4" - 13'1"	67"	73"	6'3" - 7'0"
13'2" - 14'0"	77"	83"	6'2" - 7'1"

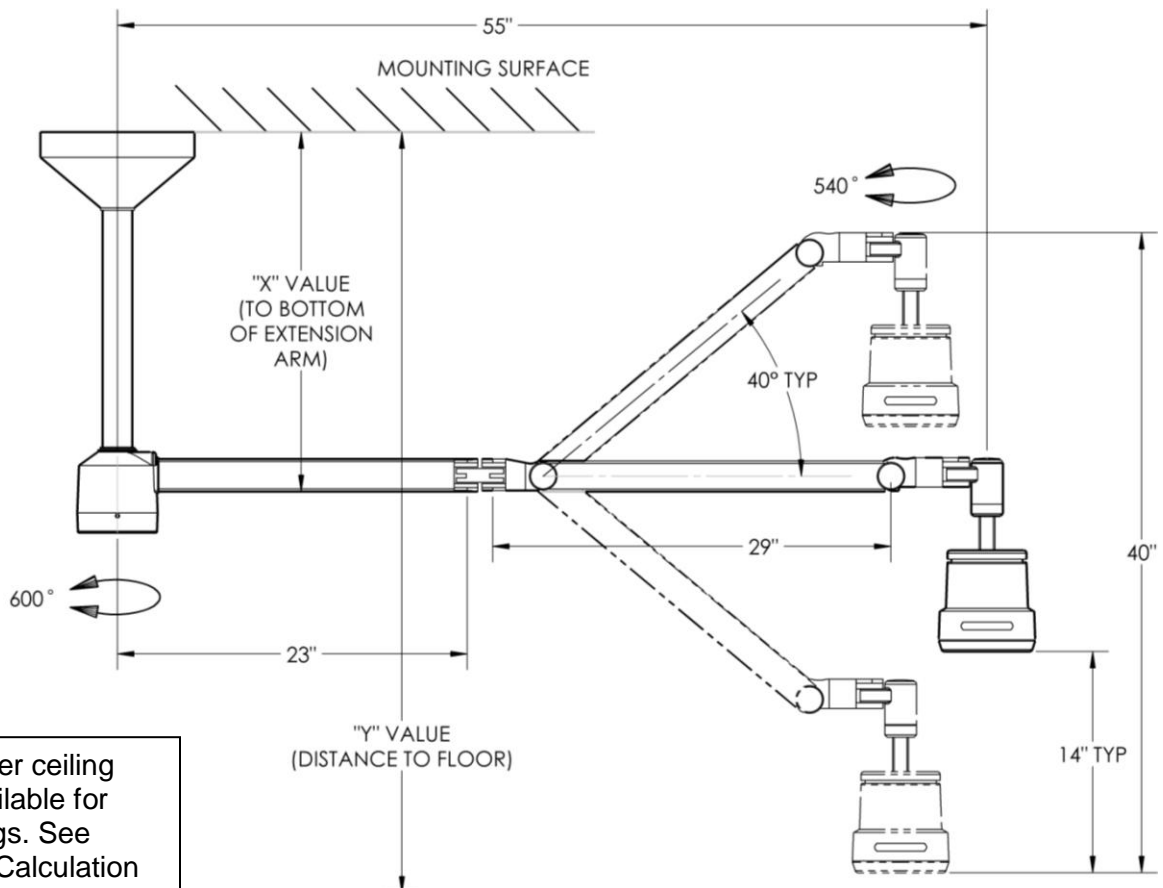

**NOTE:** Longer ceiling rods are available for higher ceilings. See Ceiling Rod Calculation on page 11.

Figure 1: Single Ceiling Mount Ceiling Rod Calculation

# Ceiling Calculation: Double Mount Dimensions

**!** Use the following table to select the correct length ceiling rod for your application.  
Ceiling Rod Calculation, Double Ceiling Mount

Ceiling Mounting Height "Y"-Value	Ceiling Rod Length	"X"-Value	Head room to bottom of extension arm (Y-Value – X-Value)
8'0" - 8'10"	16"	23"	6'3" - 6'11"
8'11" - 9'8"	25"	32"	6'3" - 7'0"
9'9" - 10'5"	35"	42"	6'3" - 6'11"
10'6" - 11'2"	44"	51"	6'3" - 6'11"
11'3" - 12'0"	53"	60"	6'3" - 7'0"
12'1" - 12'3"	63"	70"	6'3" - 6'5"
12'4" - 13'2"	67"	74"	6'3" - 7'0"
13'3" - 14'0"	77"	84"	6'1" - 7'0"

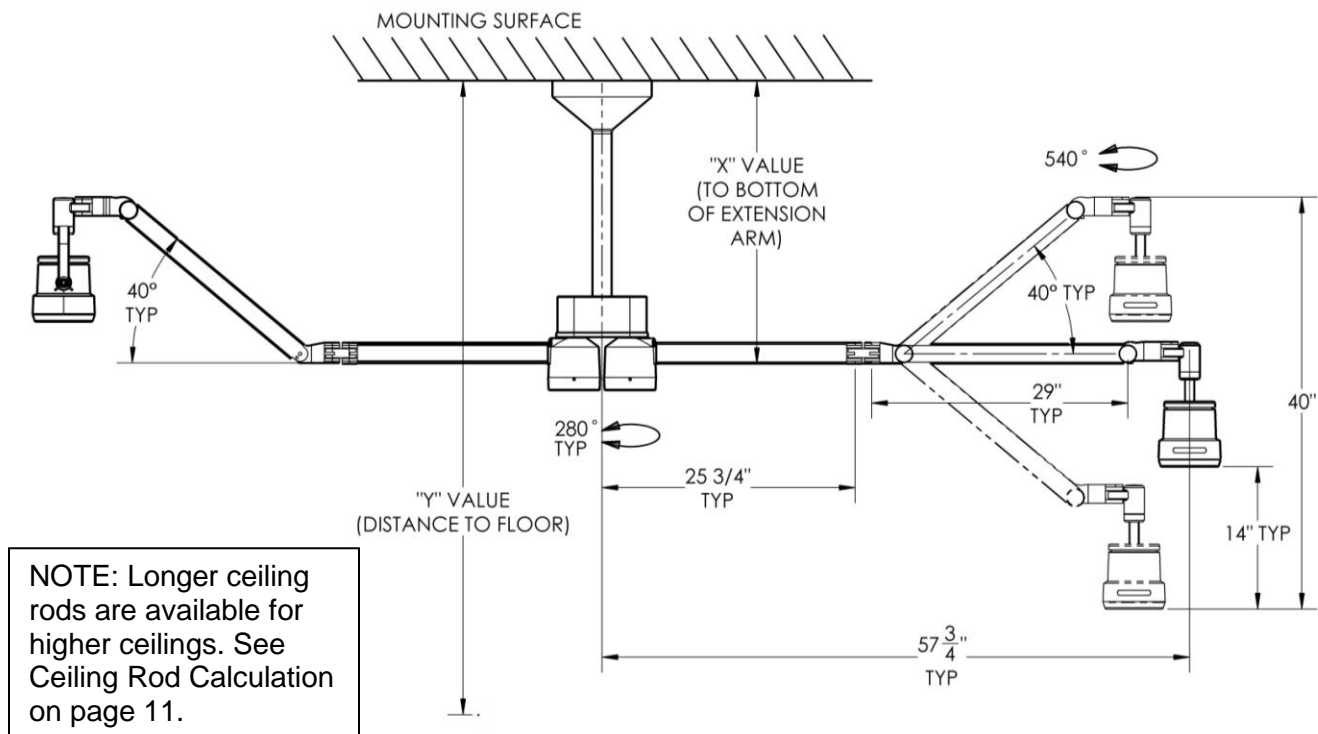

Figure 2: Double Ceiling Mount Ceiling Rod Calculation

## Ceiling Mount Pre-Installation Guidelines

**SPECIAL NOTE:** Installation and repair of this equipment should be performed by qualified persons only. Medical Illumination International, Inc. does not warranty any damage occurring as a result of improper installation. It is recommended that this installation manual be completely reviewed prior to installation.

Before installation, check to insure the following minimum conditions are provided:

Ceiling Mount	Weight: Lb	Moment: Ft Lb
Single Ceiling	70	215
Double Ceiling	115	350

← recommended

Medical Illumination strongly recommends that the ceiling structure be designed to the weights and moments for the worst case (double ceiling). Designing for the heaviest model with the highest load/torque will provide adequate support for the heaviest, and will not significantly increase the cost of the lightest. The design margin will also allow for flexibility for future product upgrades.



**A structural mount that does not meet these minimum conditions can cause serious injury and/or property damage.**



**A sloped or vaulted ceiling will require a level mounting surface be constructed that meets the above listed requirements.**

- The ceiling structure must be strong enough to support the weight and rigid enough to constrain rotation to less than 0.1° at the ceiling casting.
- The equipment may be mounted directly over a 4-0 junction box. Input power supply lines should be wired in accordance with all applicable building codes.
- The supply circuit line must be as follows:  
100-240VAC, 50/60 Hz, single phase, three wire, capable of supplying 160 Watts.
- The equipment is not deemed compatible with any sort of electrical dimming device. Use line voltage only.
- The power supply circuit line must be routed and wired to the wire harness in compliance with all applicable building codes.



**Failure to provide a circuit meeting these minimum standards or complying with local building codes can cause a shock hazard.**

Check the length of the ceiling rod supplied to make sure that it is the proper length to install and operate the light without interference or over reach (see Figure 1 or Figure 2).



### Means of Isolation

The Means of Isolation, disconnects (Isolates) the light from the source of power. This isolation makes it safe to work on the light. In the case of a ceiling mounted light, the means of isolation is the circuit breaker that supplies the power to the circuit. In the case of the Wall, floor or Floor UPS, the means of isolation is the cord, unplugging the cord isolates the light from power.

## Section 3

# Ceiling Structure Construction and Mounting

The Ceiling Mount system will experience various level of dynamic off center moment during regular use. Therefore, it is crucial that the ceiling structure to be strong enough to uphold the weight of the system and support the positioning arms and light head without deflection. The owner and/or owner's contractor has the final responsibility for the strength and rigidity of the ceiling structure. An inadequate ceiling may result in unintended drift and/or equipment damage.

Because the ceiling structure is the owner's responsibility, the design and construction recommendation shown below covers only one of the many possible alternatives that can be used. Medical Illumination highly recommends that the owner consult a structural engineer prior to designing and installing the ceiling structure.

### Recommended Ceiling Structure Construction Details

The illustrations below are suggested mounting schemes per 2001 California Building Code – Section 1632A: Anchorage and Seismic. For any other mounting scheme, please consult a structural engineer and/or professional contractor for the best solution for your situation. Installation and repair of this equipment should be performed by qualified persons only. Medical Illumination does not warranty any damage occurring as a result of improper installation.

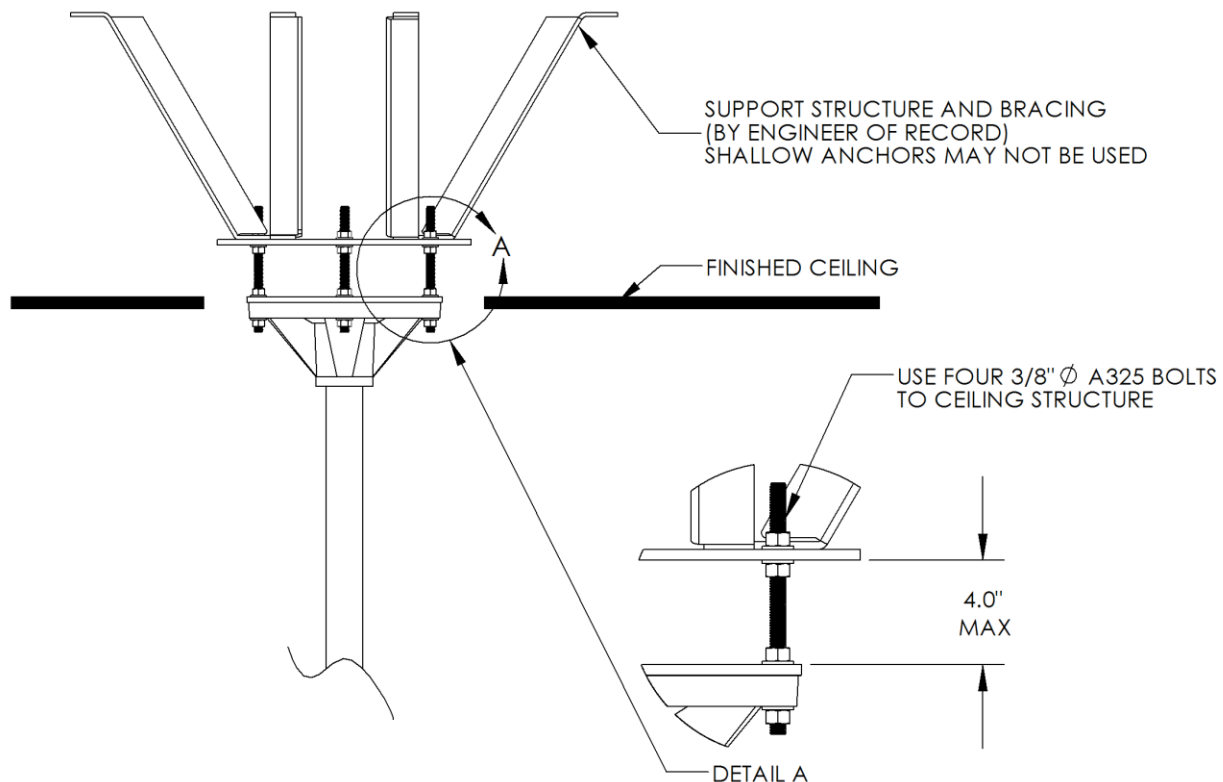

Figure 3: Recommended Ceiling Structure Construction

## Section 3

### Ceiling Structure Construction and Mounting

**⚠** Improper fastening of the ceiling casting can cause serious injury and/or property damage.

- Mount the Ceiling casting to the ceiling structure using four  $\frac{3}{8}$ " DIA A325 bolts with nuts and washers as shown in Figure 3: Recommended Ceiling Structure Construction.

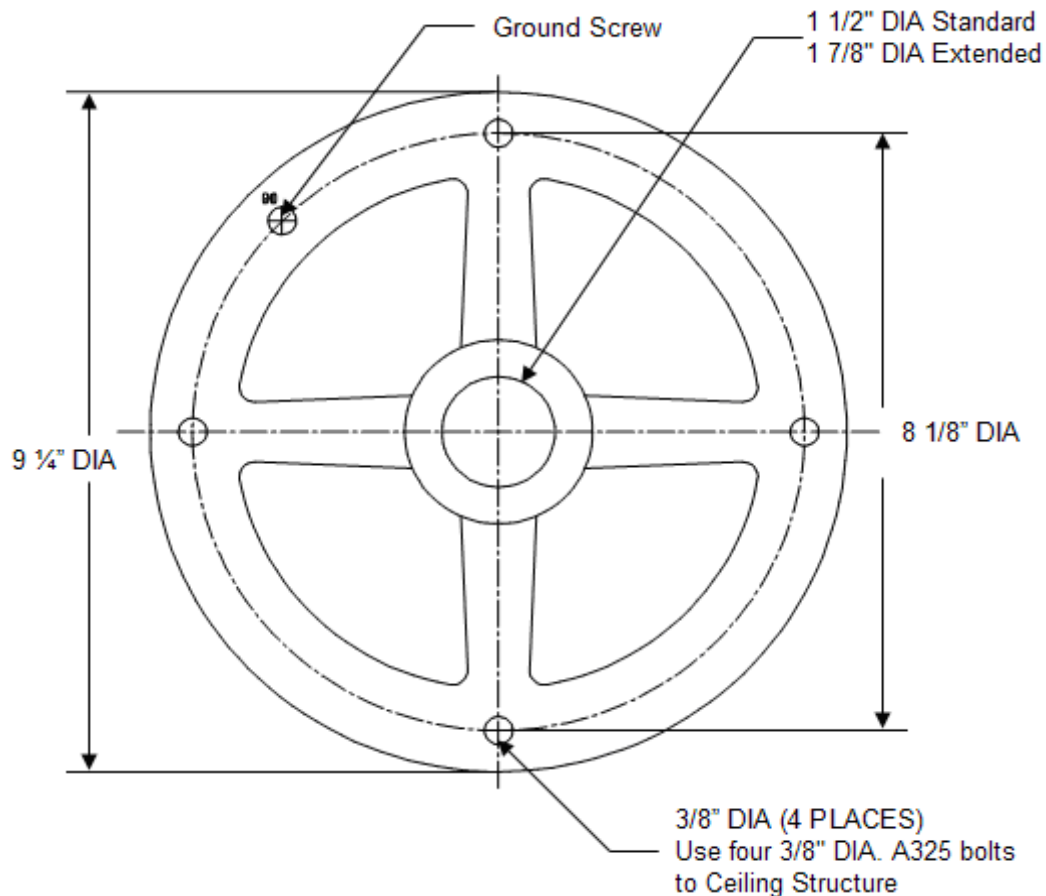

Figure 4: Ceiling Casting Mount Diagram

## Extended Ceiling Mount Installation For 10'2" – 14' (3.23m-4.27m) Ceilings

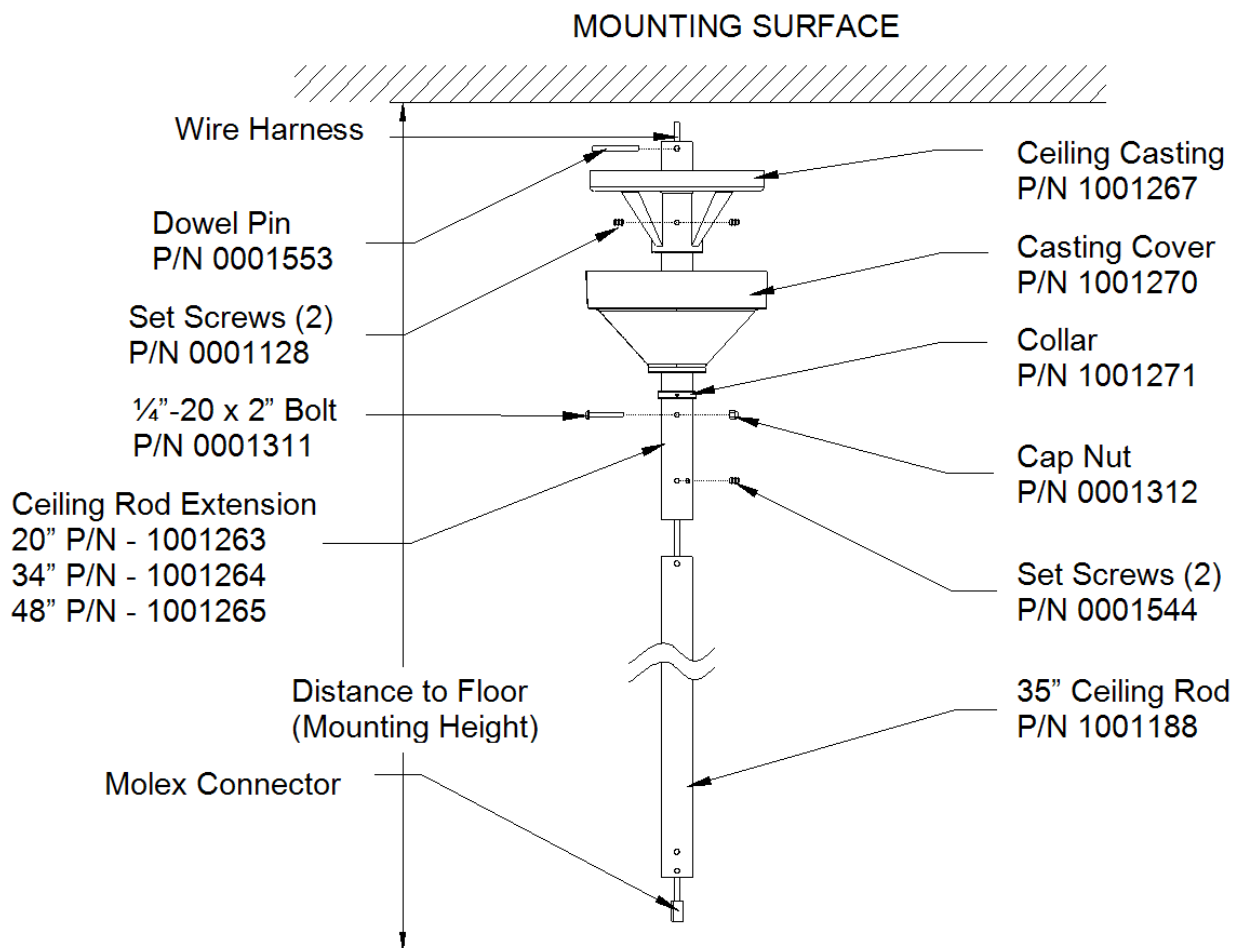

Figure 5: Extended Ceiling Mount Installation

Insert the ceiling rod up through the ceiling casting until the hole in the ceiling rod becomes visible (see Figure 5: Extended Ceiling Mount Installation). Insert the dowel pin into the hole in the ceiling rod and lower the rod in the ceiling casting, making sure the pin is seated securely in the indentation on the ceiling casting. Securely tighten the two set-screws located in the casting.



**Failure to install the dowel pin can cause the arm/head assembly to fall from the ceiling causing serious injury and/or property damage.**

The ceiling casting must be properly grounded during installation. This can be done by mounting the casting to a suitable material that will function as a ground conductor, or a wire lead that must be attached to the ground screw on the casting then routed to proper ground.

### Extended Ceiling Mount Installation (cont'd)

**Note: Ceiling rod must be plumb. Adjust the nuts/washers in Figure 3 accordingly.**

Note: The ceiling casting itself must be electrically grounded to maintain proper grounding reliability.



**If ceiling rod is not plumb, unwanted arm drifting may occur.**

- Feed the wire harness through the ceiling rod extension and route to a junction box. Leave sufficient wire to extend slightly beyond the bottom of the ceiling rod. **Important:** To achieve proper grounding reliability, the green ground wire from the wire harness **MUST** be properly fastened to the grounding screw located on the ceiling casting (see
- Figure 4: Ceiling Casting Mount Diagram). Make all electrical connections in compliance with all applicable electrical codes.



**Failure to comply with local electrical codes can cause a shock hazard.**

- Slide the casting cover up the rod extension and over the casting. Similarly, slide the collar to the casting cover, then tighten the set screw to hold the cover in place.
- Feed the wire harness through the 35" ceiling rod with the rod in the direction shown. Slide ceiling rod up through ceiling rod extension until the holes in the ceiling rod align with the upper holes in the ceiling rod extension. Insert a 1/4"-20 x 2" bolt carefully, making certain not to damage the wire harness, and then fasten the cap nut. Secure rods in place with the two set screws provided.
- See Single Ceiling Mount Installation (page 19) or Double Ceiling Mount Installation (see page 22) and to complete the assembly.

# Single Ceiling Mount Installation

## GENERAL INFORMATION

 **Installation and repair of this equipment should be performed by qualified persons only. Medical Illumination does not warranty any damage occurring as a result of improper installation.**

The shipping cartons contain a light head assembly, an arm assembly, a ceiling casting, casting cover, collar, bolt cover, ceiling rod, hardware kit, wire harness, and an Installation and Service Manual.

**Notes:** There are 3 standard length rods for different ceiling heights. Extended ceiling rod kits are available for ceilings over 10'2". Verify that your ceiling rod length is correct for your ceiling height (see "Ceiling Rod Calculation" on page 11). If not correct please contact customer service.

Prior to installation insure that all components shown in "**Error! Reference source not found.**" are present.

 **When removing parts from the shipping carton, be careful not to damage the components. Important: thoroughly check each box for parts that may be located in areas that can be overlooked.**

## Single Ceiling Mount Installation (cont'd)

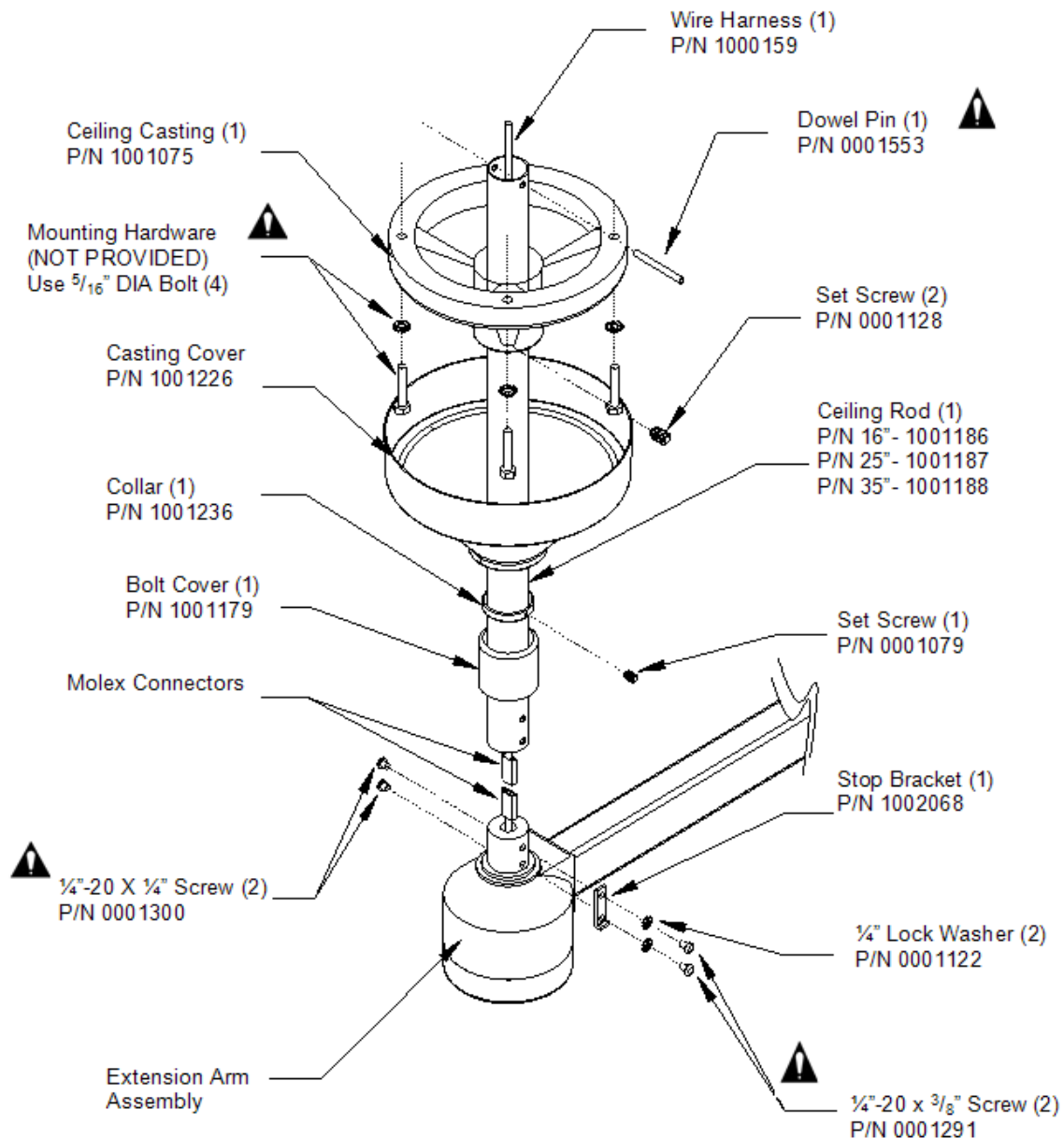

**Figure 6: Single Ceiling Mount Installation**

- Insert the ceiling rod up through the ceiling casting until the hole in the ceiling rod becomes visible. Insert the dowel pin into the hole in the ceiling rod and lower the rod in the ceiling casting, making sure the pin is seated securely in the indentation on the ceiling casting. Securely tighten the two set-screws located in the casting.

**⚠ Failure to install the dowel pin can cause the arm/head assembly to fall from the ceiling causing serious injury and/or property damage.**

## Single Ceiling Mount Installation (cont'd)

The ceiling casting must be properly grounded during installation. This can be done by mounting the casting to a suitable material that will function as a ground conductor, or a wire lead that must be attached to the ground screw on the casting then routed to proper ground.

Note: Ceiling rod must be plumb. Adjust the nuts/washers in Figure 3 accordingly.

Note: The ceiling casting itself must be electrically grounded to maintain proper grounding reliability.



**If ceiling rod is not plumb, unwanted arm drifting may occur.**

- Feed the wire harness through the ceiling rod extension and route to a junction box. Leave sufficient wire to extend slightly beyond the bottom of the ceiling rod. Important: To achieve proper grounding reliability, the green ground wire from the wire harness MUST be properly fastened to the grounding screw located on the ceiling casting. Make all electrical connections in compliance with all applicable electrical codes.



**Failure to comply with local electrical codes can cause a shock hazard.**

- Slide the casting cover up the rod over the casting. Similarly, slide the collar to the casting cover, then tighten the set screw to hold the cover in place. Feed the wire harness through the ceiling rod with the rod in the direction shown.



**Do not install the extension arm with the light head attached. Installation with the light head attached can cause damage to the light. Refer to the procedure for installing the head to the arm after the bracket and arm are installed.**

- Slide the bolt cover up onto the ceiling rod as shown in Figure 6, then raise the extension arm to the ceiling rod and plug the Molex connectors together. Push the wire into the ceiling rod while inserting the transformer housing into the rod. Secure the housing to the ceiling rod using the four supplied bolts as shown. Two 1/4"-20 x 1/4" screws must be installed on one side of the ceiling rod. Two 1/4"-20 x 3/8" screws and lock washers must be used to mount the stop bracket on the other side of the rod. Be sure the bend on the stop faces down, towards the arm.



**Failure to install the stop clip subassembly can cause damage to the light fixture.**



**Failure to install or tighten the 1/4"-20 socket head cap screw can cause the arm/head assembly to fall causing serious injury and/or property damage.**

- Complete the installation by lowering the bolt cover onto the transformer housing.
- See the instructions for "Light Head-Arm Installation" on page 33 to complete the assembly.

# Double Ceiling Mount Installation

## GENERAL INFORMATION

 **Installation and repair of this equipment should be performed by qualified persons only. Medical Illumination does not warranty any damage occurring as a result of improper installation.**

The shipping cartons each contain a light head assembly and an arm assembly. One of the cartons also contain a ceiling casting, casting cover, collar, ceiling rod, double mount assembly, hardware kit, wire harness, and an Installation and Service Manual.

Note: There are 3 standard length rods for different ceiling heights. Extended ceiling rod kits are available for ceilings over 10'6". Verify that your ceiling rod length is correct for your ceiling height (see "Ceiling Rod Calculation" on page 11). If not correct please contact customer service.

Prior to installation insure that all components shown in "**Error! Reference source not found.**" are present.

 **When removing parts from the shipping carton, be careful not to damage the components. Important: thoroughly check each box for parts that may be located in areas that can be overlooked.**

## Double Ceiling Mount Installation (cont'd)

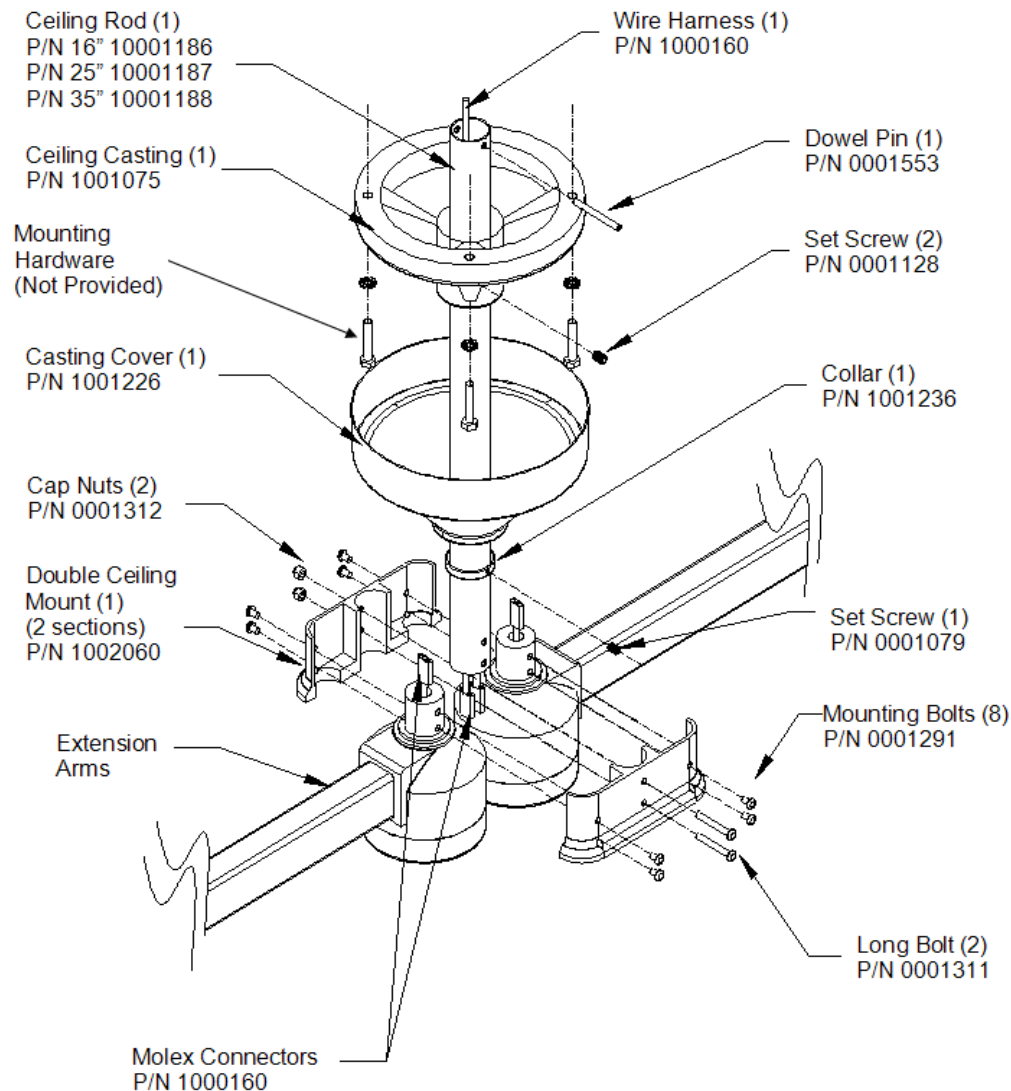

**Figure 7: Double Ceiling Mount Installation**

Insert the ceiling rod up through the ceiling casting until the hole in the ceiling rod becomes visible. Insert the dowel pin into the hole in the ceiling rod and lower the rod in the ceiling casting, making sure the pin is seated securely in the indentation on the ceiling casting. Securely tighten the two set-screws located in the casting.

**⚠ Failure to install the dowel pin can cause the arm/head assembly to fall from the ceiling causing serious injury and/or property damage.**

The ceiling casting must be properly grounded during installation. This can be done by mounting the casting to a suitable material that will function as a ground conductor, or a wire lead that must be attached to the ground screw on the casting then routed to a ground point.

### Double Ceiling Mount Installation (cont'd)

**Note: Ceiling rod must be plumb. Adjust the nuts/washers in Figure 3 accordingly.**

**Note: The ceiling casting itself must be electrically grounded to maintain proper grounding reliability.**



**If ceiling rod is not plumb, unwanted arm drifting may occur.**

Feed the wire harness through the ceiling rod extension and route to a junction box. Leave sufficient wire to extend slightly beyond the bottom of the ceiling rod. Important: To achieve proper grounding reliability, the green ground wire from the wire harness MUST be properly fastened to the grounding screw located on the ceiling casting (see

Figure 4: Ceiling Casting Mount Diagram). Make all electrical connections in compliance with all applicable electrical codes.



**Failure to comply with local electrical codes can cause a shock hazard.**

Slide the casting cover up the rod over the casting. Similarly, slide the collar to the casting cover, then tighten the set screw to hold the cover in place. Feed the wire harness through the ceiling rod with the rod in the direction shown.



**Do not install the extension arm with the light head attached. Installation with the light head attached can cause damage to the light. Refer to the procedure for installing the head to the arm after the bracket and arm are installed**

Bring one section of the double ceiling mount casting to the ceiling rod and fasten it to the rod with the 2" long bolts (P/N 0001311) and cap nuts (P/N 0001312). Tighten the cap nuts just enough to hold the section in place; they do not need to be fully tightened at this time. Bring an arm assembly to the double mount section and fasten the transformer housing into the extension arm mounting cavity with two 7/16" long mounting screws (P/N 0001291) with the accompanying flat washer. Install the other arm assembly to the section with two more 7/16" long screws. Route the wire and Molex connector from the ceiling rod into the wire channel as shown in "Figure 8: Wire Harness Positioning" and (Figure 9: Wire Channel). Plug the connector at the end of each arm assembly to the mating Molex connector from the wire harness. Place each set of wires within the channel area.

## Double Ceiling Mount Installation (cont'd)

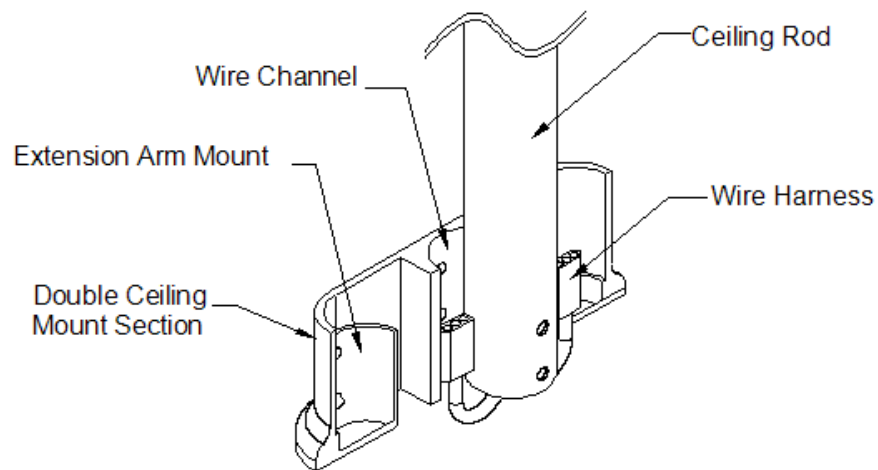

**Figure 8: Wire Harness Positioning**

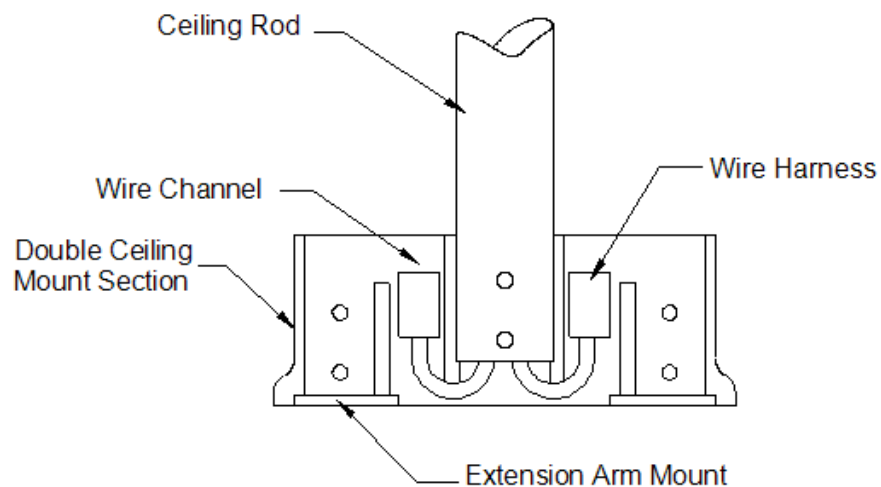

**Figure 9: Wire Channel**

Position the two extension arms as shown in “Figure 7: Double Ceiling Mount Installation” to allow for easier mounting of the remaining double-mount section. Firmly press the fastened double ceiling mount section against the ceiling rod. While firmly holding the double ceiling mount section with arms attached in place, remove only the cap nuts from the 2” long bolts. It is strongly recommended that a second person hold the arms in place while the nuts are removed. Place the remaining double ceiling mount section onto the bolts. Be sure the wires are enclosed within the wire channel to avoid pinching them. Replace the cap nuts and fully tighten. Install the remaining four  $\frac{3}{8}$ ” long mounting screws and then fully tighten all eight screws.

### Double Ceiling Mount Installation (cont'd)

 **Failure to tighten the cap nuts for the 2" long bolts can cause the arm/head assembly to fall causing serious injury and/or property damage.**

 **Failure to install or tighten all eight of the  $\frac{3}{8}$ " mounting screws can cause the arm/head assembly to fall causing serious injury and/or property damage.**

Check to make sure that the wire connections are seated far enough into the double casting enclosure. Fasten the cover plates to the casting enclosure using the four  $\frac{3}{8}$ " long pan-head screws (P/N 0001319) and plastic grommets (P/N 0001306) supplied in the hardware kit.

See the instructions for "Light Head-Arm Installation" on page 33 to complete the assembly.

## Wall Mounted Light Installation GENERAL INFORMATION

The shipping cartons contain a light head assembly, arm assembly, a wall bracket assembly with a hospital grade plug attached, hardware kit, and an Installation and Service Manual. (Mounting hardware for attaching the wall bracket to the wall is not supplied).

Prior to installation ensure that all components shown on “ ” are present.

**⚠** When removing parts from the shipping carton, be careful not to damage the components. Important: thoroughly check each box for parts that may be located in areas that can be overlooked.

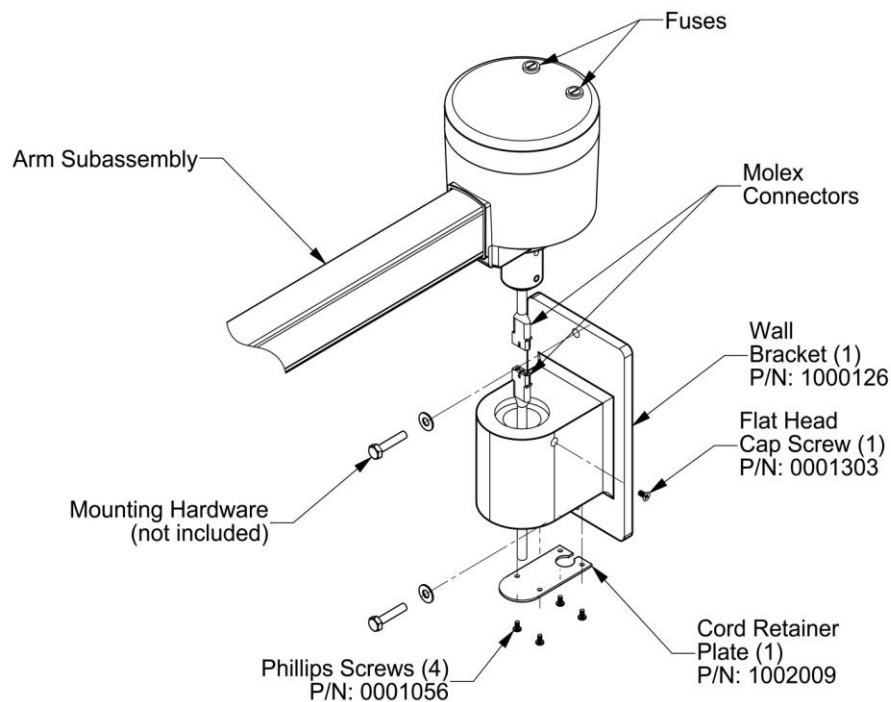

Figure 10: Wall Mount Installation

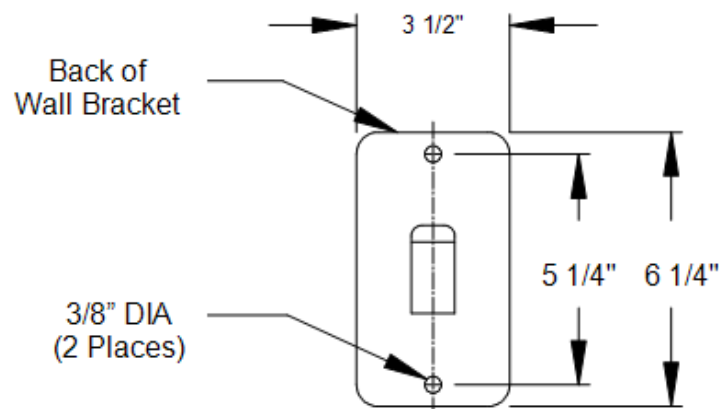

Figure 11: Wall Bracket Mounting Diagram

## Wall Mounted Light Installation

**⚠** Improper fastening of the wall bracket can cause serious injury and/or property damage. Make certain the installation is capable of supporting a load of at least 65 pounds and an off center moment of 195 ft-lbs.

**⚠** The supply circuit line must be as follows: 100-240VAC, 50/60 Hz, single phase, three wire, capable of supplying 120 Watts @ 2A.

**⚠** The equipment is not deemed compatible with any sort of electrical dimming device. Use line voltage only. To maintain proper grounding reliability, the ground wire connections with the wall bracket must be kept properly fastened at all times

**⚠** Do not install the extension arm with the light head attached. Installation with the light head attached can cause damage to the light. Refer to the procedure for installing the head to the arm after the bracket and arm are installed.

### Recommended Wall Structure Construction Details

The illustrations below are suggested mounting schemes per 2001 California Building Code – Section 1632A: Anchorage and Seismic. For any other mounting scheme, please consult a structural engineer and/or professional contractor for the best solution for your situation. Installation and repair of this equipment should be performed by qualified persons only.

#### Wall mounting with load anchor or stud anchor

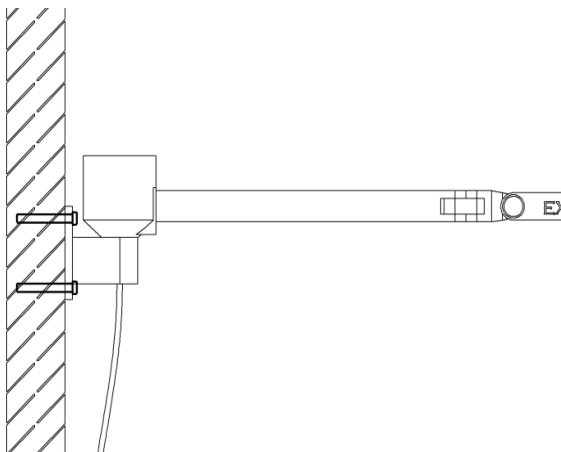

Concrete Wall (3000 PSI min., 6" thick min.):  
Use two  $\frac{3}{8}$ " Dia HILTI KB3 Expansion Anchors or approved equivalent bolts (min. embed. 3"). See Figure 12. Stud Anchor Installation. Also see HILTI technical document ESR-2302 for additional concrete anchoring information.

#### Wall mounting with Backing Plate (not provided)

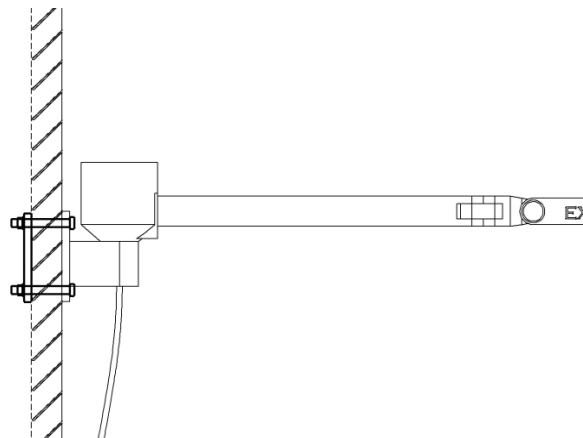

Lattice stone, cinder block, etc. (min.  $\frac{5}{8}$ " wall board thickness):  
Use two  $\frac{3}{8}$ " Dia A307 Bolts with nuts/washers to Backing Plate

### Wall Mounted Light Installation (cont'd)

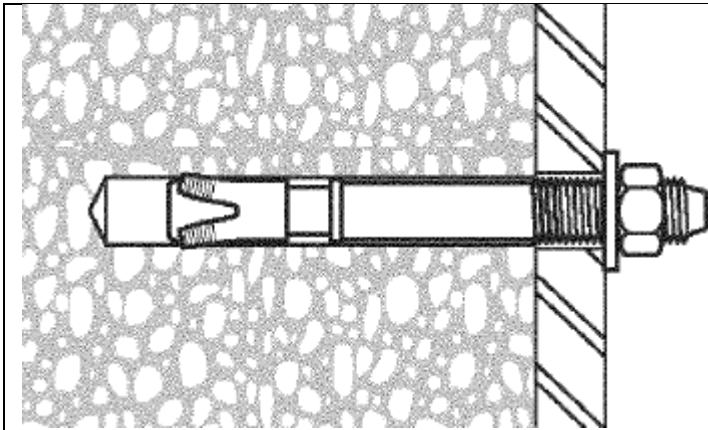

Figure 12. Stud Anchor Installation

Drill hole according to the diameter of the stud anchor  
Thoroughly clean hole – removing all debris  
Insert anchor into hole (min. embed 3")  
Torque the nut down against the washer to 20 ft-lb (see HILTI tech. doc. ESR-2302 Table 1 for reference)

Remove the four screws holding the cord retainer plate in place. Carefully pull the plate away from the wall bracket to expose the Molex connector. **DO NOT use excessive force during this procedure or in any way loosen or disconnect the green wires within the bracket.**



**Failure to comply with local electrical codes can cause a shock hazard.**

Bring the extension arm over the wall bracket and feed the Molex connector from the transformer housing into the bracket while inserting the housing into the bracket. Secure the housing to the bracket with the flat head cap screw provided.

Bring the cord retainer plate up to the bottom of the wall bracket and plug the Molex connector at the end of the power cord to the connector from the transformer. Route the connectors and wire to the rear of the bracket (not shown). Refasten the retainer plate to the bracket with the four screws provided.

See the instructions for “Light Head-Arm Installation” on page 33 to complete the assembly.

## Floor Stand Light Installation GENERAL INFORMATION

The shipping carton contains a light head assembly, arm assembly, floor base casting, two leg assemblies, a hardware kit, and an Installation and Service Manual. A second carton contains the upright pole assembly. Prior to installation insure that all components are present.

**⚠ When removing parts from the shipping carton, be careful not to damage the components. Important: thoroughly check each box for parts that may be located in areas that can be overlooked.**

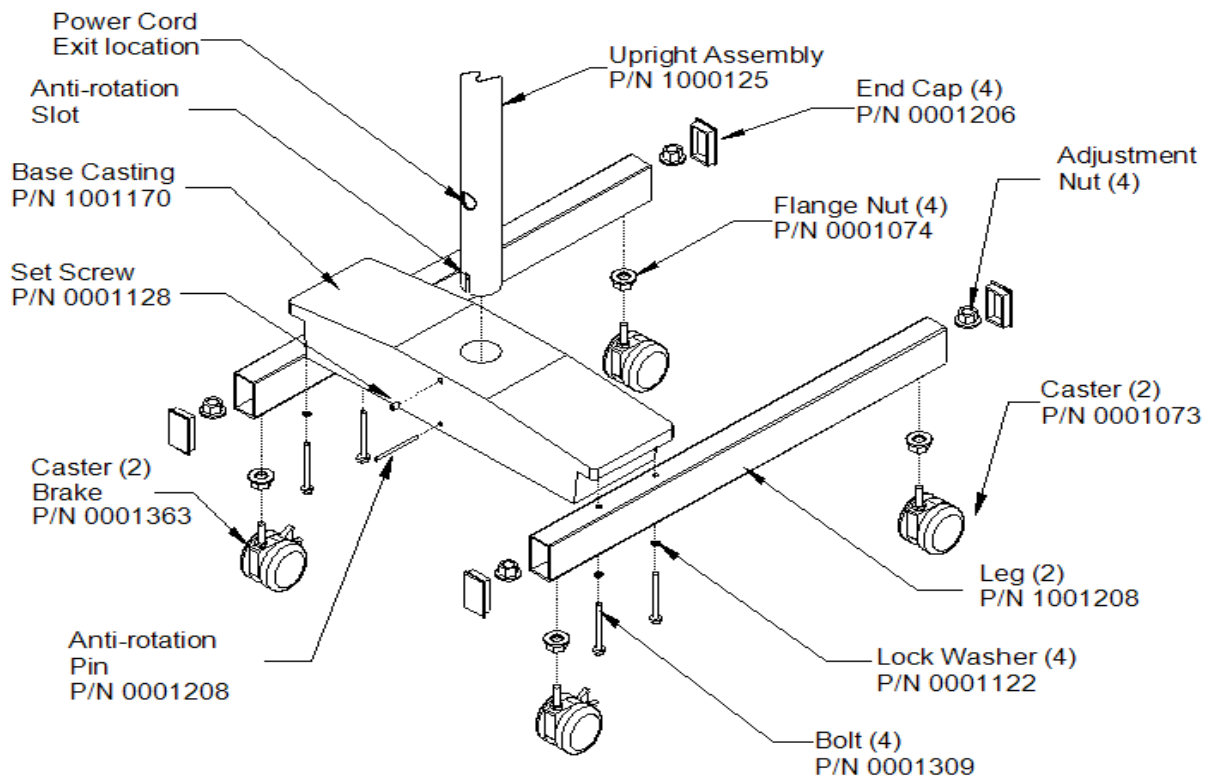

**Figure 13: Floor Stand Base Installation**

Bolt the assembled legs onto the cast iron base using four  $\frac{1}{4}$ "-20 x  $1\frac{3}{4}$ " bolts and  $\frac{1}{4}$ " lock washers. Position the floor base casting so that the set-screw in the base is at the rear of the assembly.

Insert the upright pole fully into the floor base casting so that the anti-rotation slot sits over the pin in the casting. Rotate the pole until the slots slides fully over the pin, and lower the pole completely into the base. The power cord (not shown on figure) should be in line with the set-screw. Once the pole is properly positioned, securely tighten the set-screw using the  $\frac{1}{8}$ " hex key provided.

## Floor Stand Light Installation (cont'd)

**⚠** Do not install the extension arm with the light head attached. Installation with the light head attached can cause damage to the light. Refer to the procedure for installing the head to the arm after the floor mount is assembled and the arm is in place.

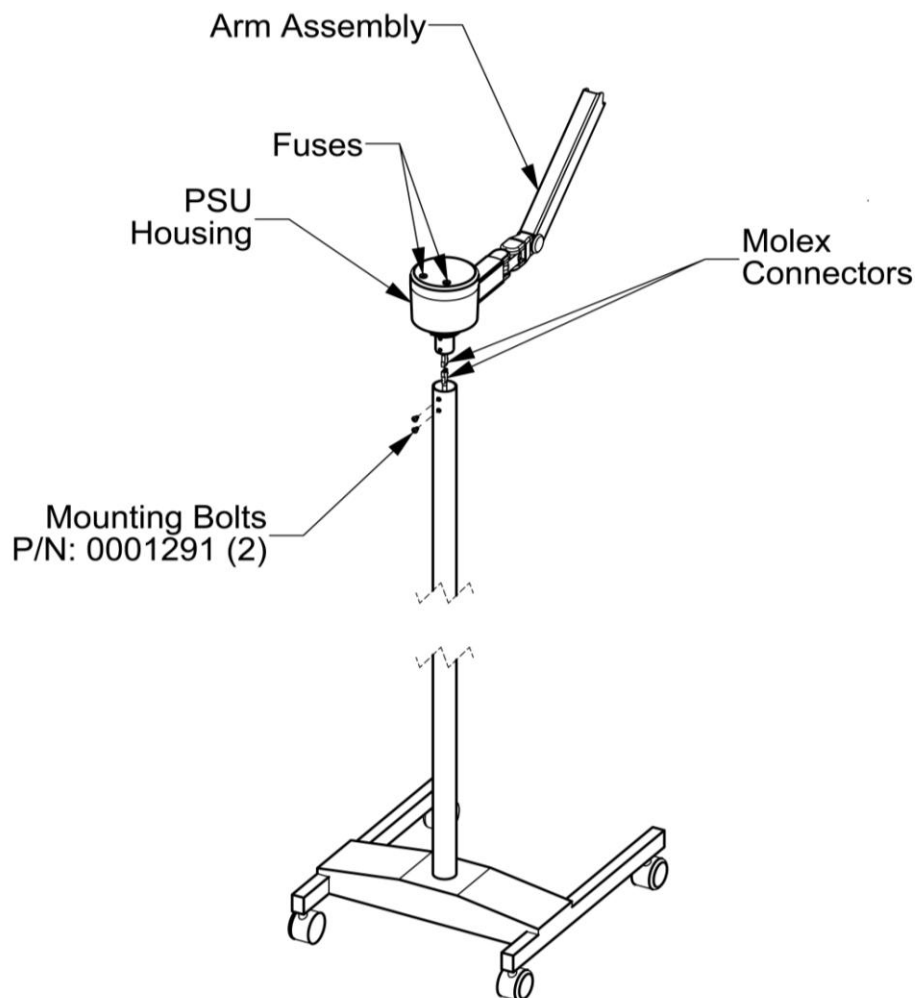

**Figure 14: Arm Assembly to Upright Pole Installation**

While securely supporting the extension arm above the upright pole, firmly grasp the cable at the end of the pole. **DO NOT** allow the cable to slip into the pole as it may be difficult to retrieve it. Connect the Molex connector from the transformer housing to the connector at the end of the pole. Remove the cable tie holding the harness in place and discard it. Carefully lower the extension arm and insert the transformer housing into the tube while pushing the wiring into the pole. Secure the housing to the pole utilizing the two  $\frac{1}{4}$ "-20 x  $\frac{3}{8}$ " bolts supplied. Tighten the bolts securely.

### Floor Stand Light Installation (cont'd)

The light arm should be between the extended legs as shown in Figure 18: Arm Assembly to Upright Pole Installation”.

To level the base, remove the end caps at the end of each leg and adjust the caster bolts and nuts. Once the base has been leveled, tighten the nuts securely and insert the leg cap in the end of each leg (see Figure 17: Floor Stand Base Installation).

See the instructions for “Light Head to Arm Installation” on page 38 to complete the assembly.

## Light Head-Arm Installation

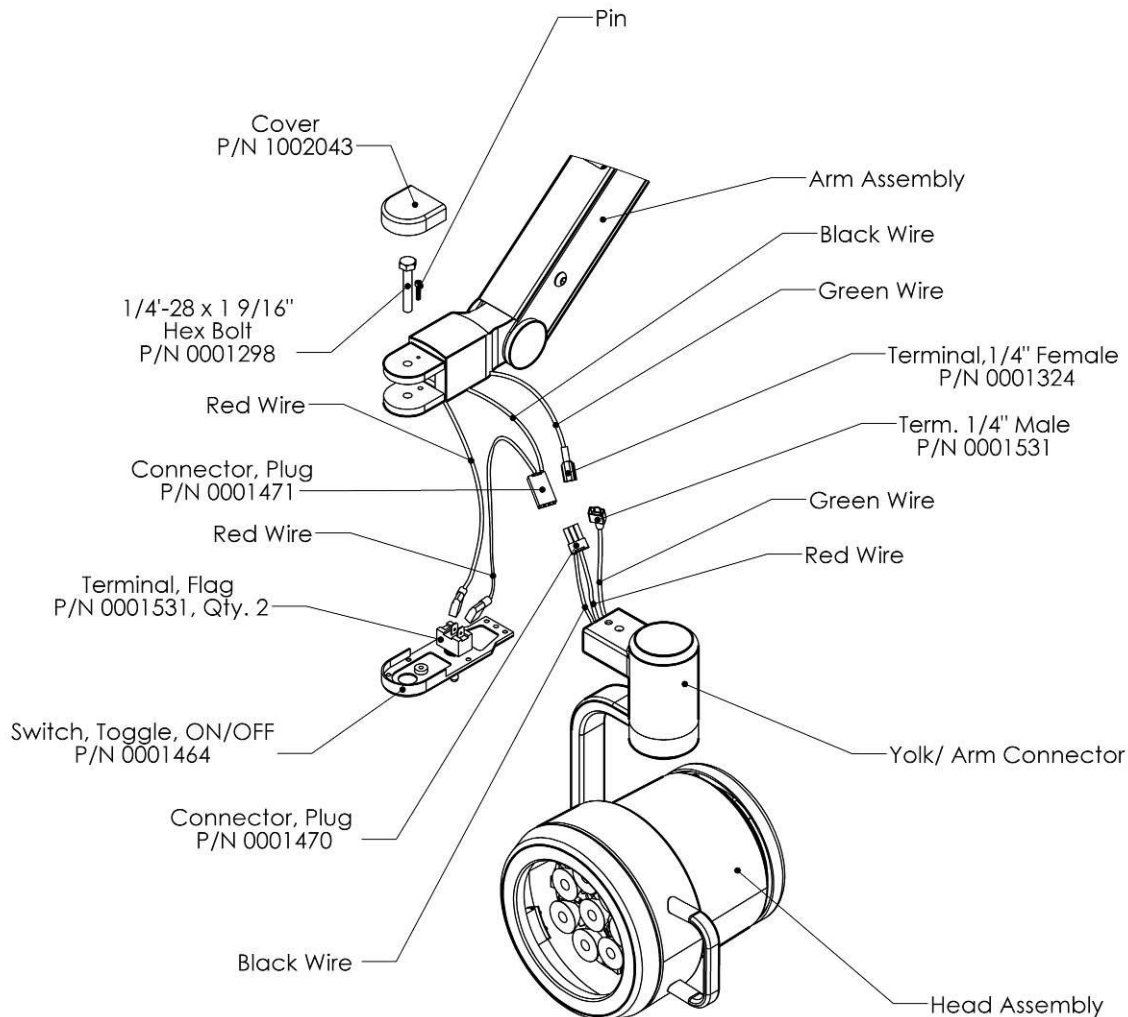













Figure 15: Light Head-Arm Installation

**⚠️ Installation and repair of this equipment should be performed by qualified persons only. Medical Illumination does not warranty any damage occurring as a result of improper installation.**

- Insert the wire set from the yoke / arm connector through the hole in the arm/wire junction.
- For a non-switched unit (not shown), connect the Molex connector and the green ground wire.

# Section 4: Safety and Maintenance Instructions

## Safety Tips

-  Only facility authorized maintenance personnel should troubleshoot the unit. Troubleshooting by unauthorized personnel could result in personal injury and/or property damage.
-  Only facility authorized personnel should repair the unit. Repair by unauthorized personnel could result in personal injury and/or property damage and could void warranty.
-  After completing a repair of the unit, ensure the unit is in proper working order. Failure to do so could result in personal injury and/or property damage
-  Do not touch the LED's or lenses directly. Body oils may significantly lower the optical performance of these parts and may cause equipment damage.
-  Follow the product manufacturer's instructions. Failure to do so could result in personal injury and/or property damage.
-  If the unit fails any part of the preventive maintenance functional checks, repair the unit before use on any patient. Failure to do so could result in personal injury and/or property damage.
-  Do not use harsh cleaners, solvents, or detergents. Failure to do so could result in equipment damage.
-  Do not use silicone-based lubricants. Equipment damage could occur.
-  Turn the power off or unplug the power cord before any repairs are started. Failure to do so could result in personal injury and/or property damage.
-  Do not pinch any wires during installation or during any repair. Pinched wires can cause an electrical shock hazard, resulting in personal injury and/or property damage.
-  Do not expose the unit to excessive moisture. Failure to do so could result in personal injury and/or property damage.
-  Do not rest articles or liquids on top of the System Two LED Surgical Lighting System. Spilled liquids will damage the light head and arm assemblies causing an electric shock hazard.

### Fuse Replacement

The Single and Dual Ceiling mounted units require 1 fuse

The Floor and Wall mounted units require 2 fuses

**IMPORTANT:** Make sure that the power supply cord is disconnected from the supply outlet before replacing the fuse(s).

1. Locate the fuse holder(s) located on the Arm Assembly

 **Use only Medical Illumination fuses P/N 0001475 (250 VAC/1.6A slow-blow, Break Capacity: 150%, 1.6A @ 60 minutes min. 1000%, 1.6A @ 20ms min to 300ms max.) if replacement is necessary. Failure to do so could result in personal injury and/or property damage.**

### LED Maintenance

- The LED life (L70) is rated such that the LED will deliver, on average, 70% lumen maintenance at 50,000 hours of operation.

 **If one or more LED(s) are off and/or generate noticeably dim light output, contact our customer service department at (818) 838-3025. The LED's are not readily replaceable by end users and should only be serviced by Medical Illumination or facility authorized maintenance personnel.**

## Arm Adjustment

**⚠** The arm has been pre-adjusted by the factory. Should further adjustment be necessary, utilize the following procedure.

Release the arm friction brake by loosening the set screw inside the Friction Adjustment Hole with an Allen wrench (3 or 4 turns). This allows the spring to move freely for a more accurate adjustment. The arm is expected to droop as the brakes are loosened.

Remove the white rubber Cover from the spring tension adjustment slot as shown.

Move the arm vertically until the adjustment nut is visible down inside the Slot.

Engage the tabs of the Adjusting Wrench into the slots in the Adjustment Nut. Turn the nut in the direction of the arrow as shown in the figure to increase the arm tension. Check the progress as you go until the required adjustment is reached.

**⚠** Do not over tighten the nut. Doing so could result in equipment damage.

When proper tension is achieved, the arm should travel up or down an equal distance when the same amount of force is applied from above or below. When moved to the maximum Up position, it should travel back down about 1-1.5 inches (until brake is set). From maximum Down position, it should travel back up about the same.

After the spring tension is adjusted, re-tighten the brake until the desired resistance is obtained.

Replace the spring tension adjustment slot cover.

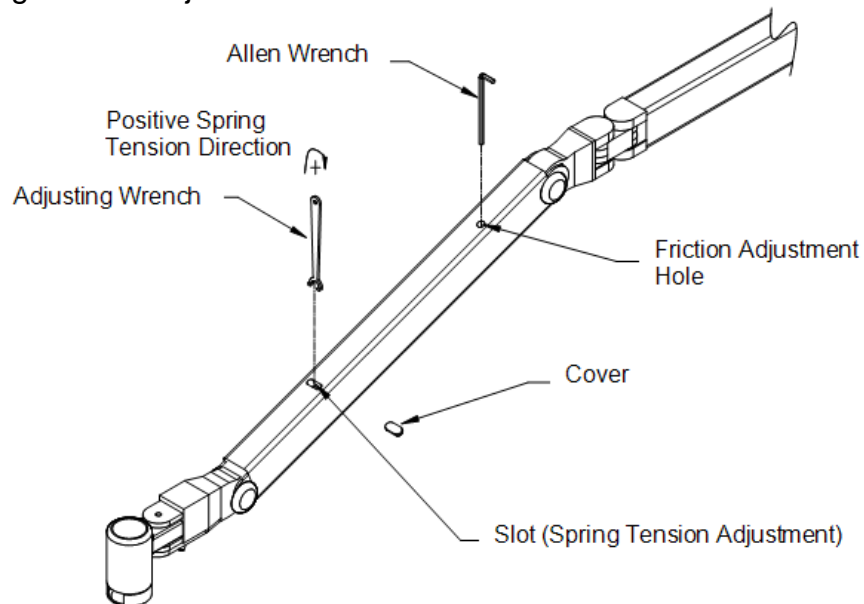

Figure 16: Arm Adjustment

### Head/Yoke Adjustment



**The head/yoke has been pre-adjusted by the factory. Should further adjustment be necessary, utilize the following procedure.**

- Gently pry off with a flat bladed screwdriver to expose nut.
- Use a MI P/N# 0001638-1, 3/4" notched socket or pliers to tighten the nut as shown. Add thread-locking liquid (e.g. Loctite™) around the inside of the nut if the nut continues to loosen during yoke rotation.



**Do not over tighten the nut. Doing so could result in equipment damage.**

- Push the yoke cap back into its original position.

### Cleaning Instructions



**Units operate at high temperatures. Allow the unit to cool at least 30 minutes before performing any maintenance. Failure to do so could result in personal injury.**

Clean the lens using glass/plastic cleaner or mild soap and water mix. It is very important to use a clean, soft cloth to avoid any scratching of the front lens. Never spray the cleaning fluid directly onto the lens surface, but instead spray into clean cloth and then wipe the lens.

Clean the light housing and arm(s) using mild soap and water mixture. Apply this mixture to a clean cloth and wipe down the light-head and arm. Never spray the cleaning fluid directly onto the light head or arm.



**Do not use harsh cleaners, solvents, or detergents. Failure to do so could result in equipment damage.**

Clean the lens using glass/plastic cleaner or mild soap and water mix. It is very important to use a clean, soft cloth to avoid any scratching of the front lens. Never spray the cleaning fluid directly onto the lens surface, but instead spray into clean cloth and then wipe the lens.



**Do not expose the unit to excessive moisture. Failure to do so could result in personal injury and/or property damage.**

# Maintenance Schedule

Function	Procedure
Front lens/Optics	Check front lens and optics to assure there are no chips, cracks, or other damage. Do not use equipment if parts are damaged. Replace damaged parts immediately.
Bolts and nuts	Check to see that all mounting and attachment screws, washers, etc. are in place and securely tightened. Replace any missing screws and re-tighten as required.
Casters	Ensure that casters are seated properly on the base assembly. Examine the base for any damage.
Moving joints/Adjustments	Check to make sure all moving joints function properly along the mounting system and head and arm system. If the articulating arm does not position properly (drifts from original position) refer to “Figure 16: Arm Adjustment” on page 36. If this does not solve the problem contact customer service as the unit may require factory repair.
Overall appearance	Check the general aesthetics. Units should be kept clean and dust free. Clean and dust as necessary.

 **Note: Maintenance schedules vary for each light depending on usage and operating instructions. An annual inspection of the equipment is recommended at a minimum.**

 **Note: Medical Illumination International Inc. recommends that the maintenance records for this equipment be kept on file at the health care facility.**

## Section 5: Troubleshooting

### General Troubleshooting



**Warning:** Disconnect the light from the power supply before attempting any of the electrical checks mentioned below.

Problem	Cause	Remedy
Light will not turn on or stay on	Power to unit is off (not plugged in)	Turn on power (plug in unit)
	Blown (open) fuse	Replace fuse
	Exposed wires are cut or damage	Replace wire assembly
	Wire not connected correctly during installation	Check all wiring connections
	Wire connections made during installation have disconnected	Reconnect wires per the instructions
	No input power to light unit	Check power input connections and circuit breakers
	Disconnected wires at switch or PSU	Reconnect wires
	No power output from PSU when input power to PSU is measured	Replace PSU
	Wire connections made during installation have been reversed	Connect proper wires together: black-black and white-white
Light does not maintain its position vertically	Sterilizable handle button not engaging power push button switch properly	Take off sterilizable handle and inspect handle post assembly with switch. Make sure handle post is tightly assembled. Make sure the button in the sterilizable handle can move freely
	Spring tension is incorrect.	Adjust spring.
Light does not maintain its position horizontally	Additional equipment was added to unit.	Remove any additional equipment from arm.
	Mounting bracket is not level. Hex nuts on pivot bolts are loose.	Adjust or shim as necessary. Remove plastic caps and adjust as necessary.

## Section 6

### General Troubleshooting (cont'd)

Light head will not rotate at yoke interface	Light head is against internal stop.	Rotate head in opposite direction.
Arm cannot be moved any lower	Arm is against internal stop.	Rotate arm in opposite direction.
Arm cannot be raised any higher	Arm is against internal stop.	Rotate arm in opposite direction.
Arm stopped moving horizontally	Arm is against internal stop.	Rotate arm in opposite direction.
Caster/casters cannot be reinstalled	Floor base has been damaged.	Contact Customer Service or Field Representative.
Upright rotates in floor stand	Upright set screw is loose. Upright is not fully seated on anti-rotation pin.	Securely tighten set screw. Reinstall upright. Ensure the upright fully seats on the anti-rotation pin seats.
Light output is irregular in shape or intensity	Input voltage does not correspond to rating label. The light head is not mounted on the proper arm (Combo models).	Check circuit to which light was installed. Remount light head on the correct arm.